

**TM 11-6625-2981-14**

**TECHNICAL MANUAL**

**OPERATOR'S, ORGANIZATIONAL, DIRECT SUPPORT**

**AND GENERAL SUPPORT MAINTENANCE MANUAL**

**OHMMETER**

**AN/PSM-43**

**INCLUDING**

**ZM-21C/U**

This copy is a reprint which includes current  
pages from Change 1.

**HEADQUARTERS, DEPARTMENT OF THE ARMY  
25 JUNE 1980**

WARNING

DANGEROUS VOLTAGES EXIST  
IN THIS EQUIPMENT

Do not come in contact with  
test leads or terminals  
during operation. Potentials  
as high as 550 Volts exist  
during operation.

DON'T TAKE CHANCES!

WARNING

To be usable for cleaning,  
the compressed air source  
must limit the nozzle pressure  
to no more than 29 pounds per  
square inch guage (PSIG).  
Goggles must be worn at all  
times while cleaning with  
compressed air.



**5**

**SAFETY STEPS TO FOLLOW IF SOMEONE IS THE VICTIM OF ELECTRICAL SHOCK**

**1**

**DO NOT TRY TO PULL OR GRAB THE INDIVIDUAL**

**2**

**IF POSSIBLE, TURN OFF THE ELECTRICAL POWER**

**3**

**IF YOU CANNOT TURN OFF THE ELECTRICAL POWER, PULL, PUSH, OR LIFT THE PERSON TO SAFETY USING A WOODEN POLE OR A ROPE OR SOME OTHER INSULATING MATERIAL**

**4**

**SEND FOR HELP AS SOON AS POSSIBLE**

**5**

**AFTER THE INJURED PERSON IS FREE OF CONTACT WITH THE SOURCE OF ELECTRICAL SHOCK, MOVE THE PERSON A SHORT DISTANCE AWAY AND IMMEDIATELY START ARTIFICIAL RESUSCITATION**



Change }  
 No. 1 }

HEADQUARTERS  
 DEPARTMENT OF THE ARMY  
 WASHINGTON D.C., 26 October 1981

Operator's, Organizational, Direct Support,  
 and General Support Maintenance Manual

**OHMMETER AN/PSM-43  
 (NSN 6625-01-102-0052)  
 INCLUDING ZM-21C/U**

TM 11-6625-2981-14, 25 June 1980, is changed as shown above.

1. Title of the manual is changed as shown above.
2. New or changed material is indicated by a vertical bar in the margin.
3. Remove and insert pages as indicated below:

<i>Remove</i>	<i>Insert</i>
i, ii, and iii .....	i, and ii
0-1 and 1-0 .....	0-1 and 1-0
4-1 and 4-2 .....	4-1 and 4-2
5-1 and 5-2 .....	None
6-1 and 6-2 .....	None
A-1 .....	A-1
D3, D-4, and D-5 .....	D3, D-4, and D-5

4. File this change sheet in front of the publication for references purposes.

By Order of the Secretary of the Army:

E. C. MEYER  
*General, United States Army*  
*Chief of Staff*

Official:

ROBERT M. JOYCE  
*Brigadier General, United States Army*  
*The Adjutant General*



TECHNICAL MANUAL }  
 No. 11-66252981-14 }

HEADQUARTERS  
 DEPARTMENT OF THE ARMY  
 WASHINGTON D.C., 25 June 1980

OPERATOR'S ORGANIZATIONAL, DIRECT SUPPORT, AND  
 GENERAL SUPPORT MAINTENANCE MANUAL  
 OHMMETER AN/PSM-43  
 (NSN 6625-01-102-0052)  
 Including ZM-21C/U

**REPORTING ERRORS AND RECOMMENDING IMPROVEMENTS**

**You can help improve this manual. If you find any mistakes or if you know of a way to improve the procedures, please let us know. Mail your letter, DA Form 2028 (Recommended Changes to Publications and Blank Forms), or DA Form 2028-2 located in back of this manual direct to: Commander, US Army Communications — Electronics Command, ATTN: DRSEL-ME-MO, Fort Monmouth, NJ 07703. In either case, a reply will be furnished to you.**

		Paragraph	Page
Chapter 0	INTRODUCTION		
	Scope . . . . .	0-1	0-1
	Index of technical publications . . . . .	0-2	0-1
	Maintenance forms, records, and reports . . . . .	0-3	0-1
	Administrative storage . . . . .	0-4	0-1
	Destruction of army electronics materiel . . . . .	0-5	0-1
	Reporting equipment improvement recommendations (EIR) . . . . .	0-6	0-1
Chapter 1	GENERAL INFORMATION AND SAFETY PRECAUTIONS		
	Safety precautions . . . . .	1-1	1-1
	Introduction . . . . .	1-2	1-1
	Equipment description . . . . .	1-3	1-1
	Relationship of units . . . . .	1-4	1-1
	Reference data . . . . .	1-5	1-1
	Equipment, accessories and documents supplied . . . . .	1-6	1-1
Chapter 2	OPERATION		
	Introduction . . . . .	2-1	2-1
	Service upon receipt . . . . .	2-2	2-1
	Controls and indicators . . . . .	2-3	2-1
	Operating procedures . . . . .	2-4	2-2
	Procedures for setting controls prior to turn-on . . . . .	2-5	2-2
	Procedures for determining operational readiness and acceptable indication . . . . .	2-6	2-2
	Operator's checks and adjustments . . . . .	2-7	2-2
	Operator's maintenance actions and schedules . . . . .	2-8	2-2
Chapter 3	FUNCTIONAL DESCRIPTION		
	Overall description . . . . .	3-1	3-1
	Major functional and circuit description . . . . .	3-2	3-1

This manual is an authentication of the manufacturer's commercial literature. The manual was not prepared in accordance with military specifications; therefore, the format has not been structured to consider categories of maintenance.

	<i>Paragraph</i>	<i>Page</i>
Chapter 4	<b>SCHEDULED MAINTENANCE</b>	
	Introduction .....	4-1 4-1
	Scheduled maintenance .....	4-2 4-1
	Cleaning .....	4-3 4-1
	Lubrication .....	4-4 4-2
	Performance test .....	4-5 4-3
Appendix A.	REFERENCES .....	A-1
Appendix B.	<b>COMPONENTS OF END ITEM LIST</b>	
Section I.	Introduction .....	B-1
II.	Integral Components of End Item .....	B-2
III.	Basic Issue Items (Not Applicable)	
Appendix D.	<b>MAINTENANCE ALLOCATION</b>	
Section I.	Introduction .....	D-1
II.	Maintenance Allocation Chart for Ohmmeter	
	AN/PSM-43 .....	D-4
III.	Tool and Test Equipment Requirements for	
	Ohmmeter AN/PSM-43 .....	D-5

**LIST OF ILLUSTRATIONS**

<i>Number</i>	<i>Title</i>	<i>Page</i>
1-1.	Ohmmeter AN/PSM-43 .....	1-0
2-1.	Packaging Diagram .....	2-1
2-2.	Controls and Indicators .....	2-2
3-1.	Functional Block Diagram .....	3-1
3-2.	Schematic Diagram .....	3-1
4-1.	Lubrication Points .....	4-2

**LIST OF TABLES**

<i>Number</i>	<i>Title</i>	<i>Page</i>
1-1.	Reference Data .....	1-1
1-2.	Equipment and Documents Supplied .....	1-2
2-1	Controls and Indicators .....	2-1
4-1.	Scheduled Maintenance Action Index .....	4-1
4-2.	Test Equipment .....	4-1



## CHAPTER 0 INTRODUCTION

### 0-1. Scope.

This manual contains instructions for the operation, organizational maintenance, and general support maintenance of Ohmmeter AN/PSM-43 hereinafter referred to as the ohmmeter.

### 0-2. Index of Technical Publications.

Refer to latest issue of DA Pam 310-4 to determine whether there are new editions, changes, or additional publications pertaining to the equipment.

### 0-3. Maintenance Forms, Records, and Reports.

a. *Reports of Maintenance and Unsatisfactory Equipment.* Department of the Army forms and procedures used for equipment maintenance will be those prescribed by TM 38-750, The Army Maintenance Management System.

b. *Report of Packaging and Handling Deficiencies.* Fill out and forward SF 364 (Report of Discrepancy (ROD) as prescribed in AR 735-11-2/DLAR 4140.55/NAVMATINST 4355.73/AFR 400-54/MCO 4430.3E.

c. *Discrepancy in Shipment Report (DISREP) (SF 361).* Fill out and forward Discrepancy in Shipment Report (DISREP) (SF 361) as prescribed in AR

55-38/NAVSUPINST 4610.33B/AFR 75-18/MCO  
P4610.19C/DLAR 4500.15.

### 0-4. ADMINISTRATIVE STORAGE.

Before placing the ohmmeter in temporary (90 days) storage, determine the serviceability of the equipment by performing the operational check procedures described in paragraph 2-2c.

### 0-5. Destruction of Army Electronics Materiel.

Destruction of Army electronics materiel to prevent enemy use shall be in accordance with TM 750-244-2.

### 0-6. Reporting Equipment Improvement Recommendations (EIR).

If your ohmmeter needs improvement, let us know. Send us an EIR. You, the user, are the only one who can tell us what you don't like about your equipment. Let us know why you don't like the design. Tell us why a procedure is hard to perform. Put it on an SF 368 (Quality Deficiency Report). Mail it to Commander, US Army Communications-Electronics Command, ATTN: DRSEL-ME-MQ, Form Monmouth, NJ 07703. We'll send you a reply.

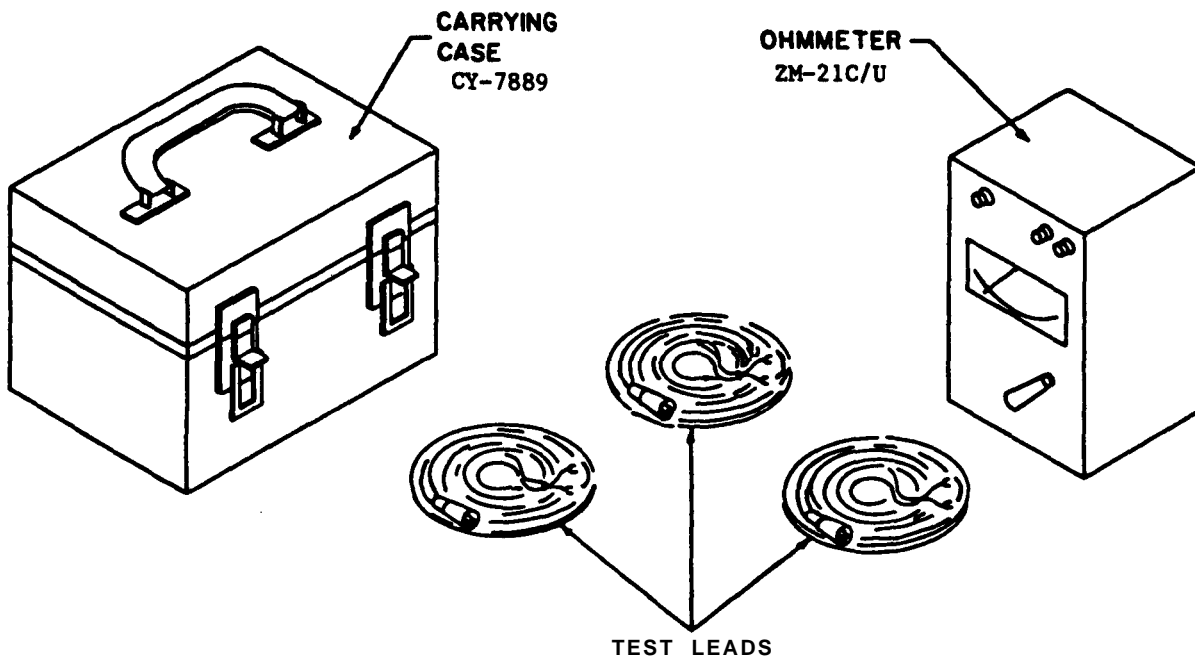

Figure 1-1. Ohmmeter AN/PSM-43

EL6TW001

CHAPTER 1

GENERAL INFORMATION AND SAFETY PRECAUTIONS

1-1. SAFETY PRECAUTIONS.

The ohmmeter generates dangerous voltages. Observe warnings.

and insulation quality tests of motors, cables, and electrical devices.

1-2. INTRODUCTION.

This manual covers the operation; servicing, and maintenance for the ZM-21C/U ohmmeter. The ZM-21C/U ohmmeter is used to determine the resistance of electric circuits and equipment.

1-4. RELATIONSHIP OF UNITS.

(See Figure 1-1) The ohmmeter is a portable self-contained unit. It has a removable case for service access.

1-3. EQUIPMENT DESCRIPTION.

The ohmmeter is the hand-driven generator type enclosed in a metal case. It measures leakage resistance of electrical circuits from 0 to 1000 Megohms. Typical uses are breakdown

1-5. REFERENCE DATA.

Table 1-1 lists the reference data for the ohmmeter.

1-6. EQUIPMENT, ACCESSORIES AND DOCUMENTS SUPPLIED.

Table 1-2 lists the equipment and documents supplied.

Table 1-1. Reference Data

Item	Data
Manufacturer	Aul Instruments, Inc. (Code 25778)
Manufacturer's Part No.	102282
Type Designation	ZM-21C/U
Size	7" High X 9" Wide X 7" Deep
Weight	Approximately 6 pounds
Scale Length	3 inches
Pointer Accuracy	Pointer indicates within 2 percent of scale length at any of the marked scale positions.
Ripple Voltage	Peak ripple voltage at ohmmeter terminals is not more than 10% of the effective voltage.
No Load Voltage	500 Volts DC
External Field Influence	Ohmmeter has sufficient magnetic shielding so that the effect of an external magnetic field of 5 oersteds will not cause a change in indication greater than 1.5% at any point on the scale between 0 and 40 Megohms.
Dielectric Strength	Ohmmeter will withstand a voltage of 1000 Volts DC without damage or flash-over.
Operating Temperature	-15°C to +55°C
Storage Temperature	-55°C to +71°C
Humidity	Up to 100%
Resistance Range	0 to 1000 Megohms

Table 1-2. Equipment and Documents Supplied

Quantity	Nomenclature	Overall Dimensions	Weight
2	Test Leads, Red	6 feet Long	Approx. 8 oz.
1	Test Leads, Black	6 feet Long	Approx. 4 oz.
1	Ohmmeter ZM-21C/U	7" High X 9" Wide X 7" Deep	6 pounds
1	Maintenance Manual TM 11-6625-2981-14	8-1/4" X 10-3/4"	
1	Case, CY-7889	8-1/2" X 6" X 6-3/4"	

CHAPTER 2

OPERATION

2-1. INTRODUCTION.

The ohmmeter will operate in the range of 0 to 1000 Megohms, primarily for use with electric equipment and machines.

2-2. SERVICE UPON RECEIPT.

a. Unpacking. Refer to figure 2-1. Cut the tape holding the flaps on the top of the carton. Open the four

flaps. Remove the cushion material from the top and sides. Remove the ohmmeter.

b. Inventory of Equipment. Refer to table 1-2 and verify that you have received all items shown in that table.

WARNING

DANGEROUS VOLTAGES EXIST  
IN THIS EQUIPMENT

Do not come in contact with test leads or terminals during operation. Potentials as high as 550 Volts exist during operation.

DON'T TAKE CHANCES!

c. Operational Checkout. Pointer should be unbroken. Glass over indicator panel should not be cracked. Check terminal posts for cracks. Place a short across terminals, crank handle, meter should read zero with crank turning at approximately 150 rpm.

2-3. CONTROLS AND INDICATORS.

Controls and indicators are illustrated in Figure 2-2. Control and indicator functions are listed in Table 2-1.

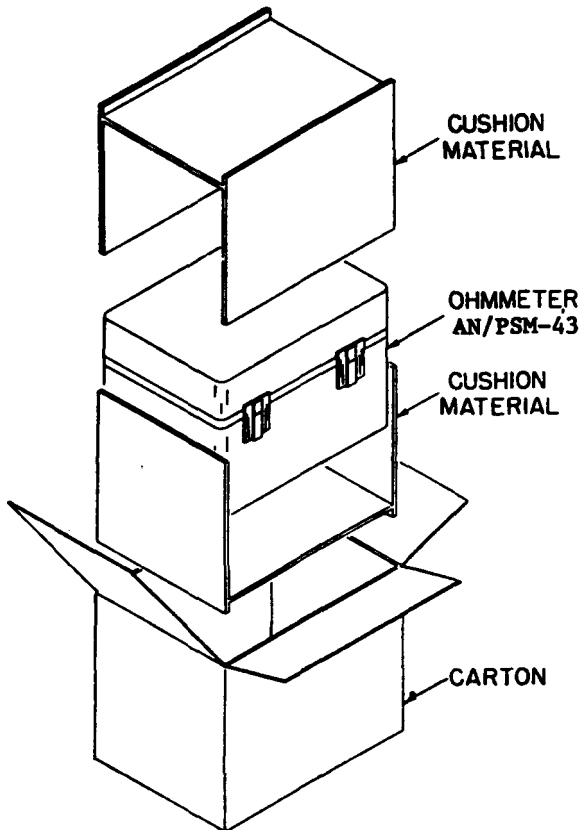

EL6TW003

Figure 2-1. Packaging Diagram

Table 2-1. Controls and Indicators

Item	Name	Function
1	Crank handle	Powers ohmmeter
2	Pointer	Indicates resistance
3	Binding post (Black)	External ground connection
4	Binding post (Red)	External line connection
5	Binding post (Green)	External guard connection

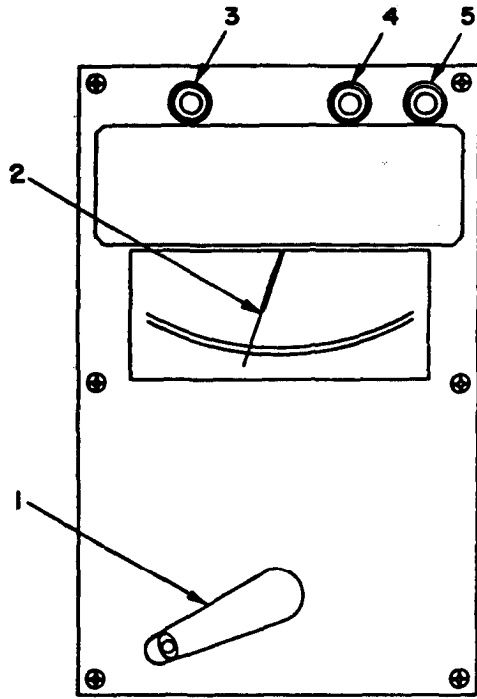

EL6TW002

Figure 2-2. Controls and Indicators

WARNING

DANGEROUS VOLTAGES EXIST  
IN THIS EQUIPMENT

Do not come in contact with test leads or terminals during operation. Potentials as high as 600 Volts exist during operation.

DON'T TAKE CHANCES!

2-4. OPERATING PROCEDURES.

To determine the insulation resistance of a circuit, connect the circuit to the terminal posts of the ohmmeter using the test leads provided and crank the ohmmeter handle. The ohmmeter pointer indicates the resistance in 0-1000 Megohms on the ohmmeter dial. The ohmmeter has a guard circuit that can be used to reduce the effect of surface leakage. A third test lead is provided for this use. When surface leakage on an insulator is suspect, connect the guard lead to the insulator. Contact with the insulator can be obtained by wrapping metal foil or a rag dampened with salt water around the insulator at its midpoint. If use

of the guard circuit reduces the indicated leakage, then the insulator must be cleaned. The hand-cranked generator is a regulated power supply. As soon as the crank is turned at about 160 rpm, any further increase in speed will have no effect on the reading. Thus, the proper cranking speed can easily be determined by finding that speed above which the meter reading does not change.

2-5. PROCEDURES FOR SETTING CONTROLS PRIOR TO TURN-ON.

Only those actions described in paragraph 2-4 are necessary for operating the ohmmeter.

2-6. PROCEDURES FOR DETERMINING OPERATIONAL READINESS AND ACCEPTABLE INDICATIONS.

WARNING

DANGEROUS VOLTAGES EXIST  
IN THIS EQUIPMENT

Do not come in contact with test leads or terminals during operation. Potentials as high as 550 Volts exist during operation.

DON'T TAKE CHANCES!

a. Disconnect ohmmeter from all circuitry and turn crank at approximately 160 rpm.

b. Meter should remain deflected to "0",  $\pm 1/16$ ".

c. Connect a short circuit across the red and black ohmmeter terminals and turn crank at approximately 160 rpm.

d. Meter should deflect to "0"  $\pm 1/16$ ".

2-7. OPERATOR'S CHECKS AND ADJUSTMENTS.

Operator's checks and adjustments are limited to those actions described in paragraph 2-6.

2-8. OPERATOR'S MAINTENANCE ACTIONS AND SCHEDULES

Operator's maintenance actions and

2-8. OPERATOR'S MAINTENANCE ACTIONS AND SCHEDULES. - continued  
 schedules are limited to those actions described in paragraph 2-6. These actions should be performed before each use or once per day, whichever is less frequent.

CHAPTER 3

FUNCTIONAL DESCRIPTION

3-1. OVERALL DESCRIPTION.

The ohmmeter is a series type which receives its power from a hand driven generator. The ohmmeter is enclosed in a metal case, containing a meter, gear driven generator and printed circuit assembly. Three test leads approximately 6 feet in length are supplied with the ohmmeter. Each lead terminates at one end in an insulated test clip. The other end of each lead is provided with a spade lug for making positive connection to the ohmmeter terminals. Each spade lug is provided with an insulating sleeve over the cord connection point.

filtered by C1 and feeds a voltage divider consisting of potentiometer R1 and fixed resistor R6. That voltage is applied to the test circuit and any conduction across the black and red terminals will cause M1 to deflect. The meter has a second coil connected in opposition to the black and red circuit. That second coil is fed by the green (guard) terminal and current in the guard circuit will oppose the deflection of the coil connected to the black and red circuit.

3-2. MAJOR FUNCTIONAL AND CIRCUIT DESCRIPTION.

Refer to the functional block diagram figure 3-1 and the schematic diagram figure 3-2. AC power generated by the generator is fed to a voltage doubling circuit consisting of C2, and CR1, CR2, CR3 and CR4. The rectified and doubled voltage is

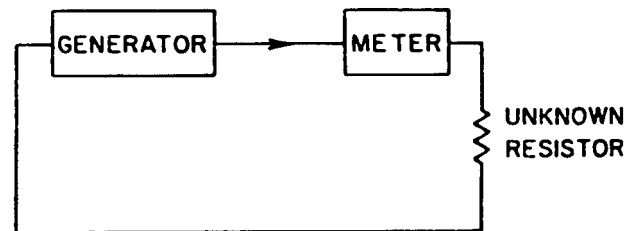

EL6TW005

Figure 3-1. Functional Block Diagram

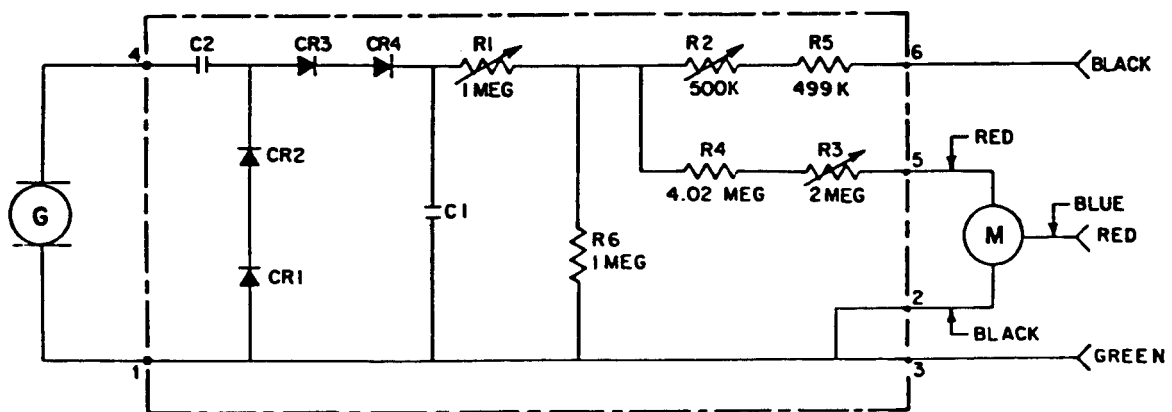

EL6TW004

Figure 3-2. Schematic Diagram





## CHAPTER 4 SCHEDULED MAINTENANCE

### 4-1. Introduction.

This chapter describes the scheduled and preventive maintenance for the ohmmeter.

### 4-2. Scheduled Maintenance.

Table 4-1 contains scheduled maintenance for the unit. Ohmmeter should be cleaned, lubricated and performance tested at 6 month intervals.

Table 4-1. Scheduled Maintenance Action Index

Periodicity	Maintenance Action	Reference
S	Cleaning	4-3
S	Lubrication	4-4
S	Performance Test	4-5

Table 4-2. Test Equipment

Nomenclature	National Stock Number
Tool kit, electronic eqpt. TK-101/G	5180-00-064-5178
Resistor, fxd film 1 Megohm ±1%	5905-00-433-9267
Resistor, fxd film 10 Megohm ±1%	5905-00-065-0585
Resistor, fxd film 100 Megohm ±1%	5905-00-049-8618
Voltmeter, electronic ME-202C/U	6625-00-972-4046

### 4-3. Cleaning.

**CAUTION**

If solvents are required for cleaning, use only alcohol or freon. Do not use trichlorotrifluoroethane (trichloroethane) as that solvent will damage some of the plastic parts. Do not use abrasives or scouring powders as they will damage the finish and may leave a residue.

a. *Exterior Cleaning.* Clean the exterior surface of all dirt or grease using a clean cloth.

**WARNING**

To be usable for cleaning, the compressed

air source must limit the nozzle pressure to no more than 29 pounds per square inch gauge (PSIG). Goggles must be worn at all times while cleaning with compressed air.

b. *Interior Cleaning.* Remove the six screws holding the ohmmeter to the case. Remove the ohmmeter from the case. Using compressed air, clean out the case. Refer to figure 4-1. Clean ohmmeter if dirt is present. Use compressed air for cleaning. Do not blow air directly into meter movement, item 1 of figure 4-1. Do not replace the ohmmeter in the case until lubrication, 4-4, has been completed.

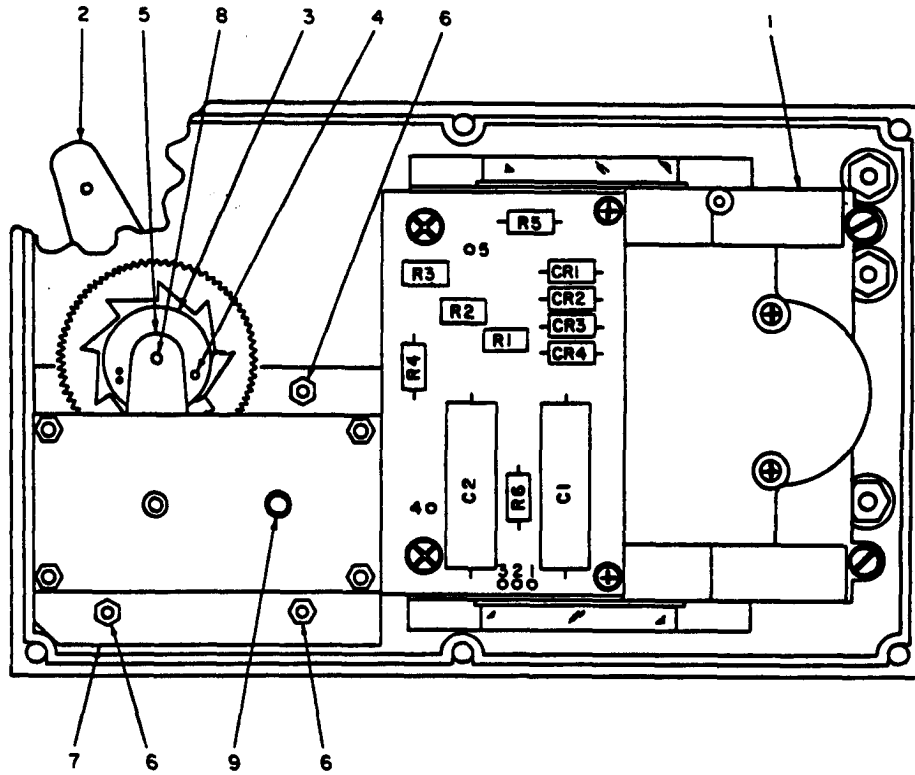

EL6TW006

Figure 4-1. Lubrication Points

**4-4. Lubrication.**

Refer to figure 4-1. Crank handle 2 must be removed to provide access for lubrication. To unscrew the crank handle from ratchet assembly 3, it is necessary to keep the ratchet assembly from turning. To lock the ratchet assembly, position a blade screwdriver between post 4 and bearing support 5. Unscrew and take off the crank

handle. Unscrew and take off three nuts and lockwashers 6. Lift out generator 7. Apply one drop of instrument oil to each end of drive shaft 8 and armature shaft 9. Put the generator in place. Screw on and tighten three nuts with lockwashers 6. Screw on crank handle 2. Replace the ohmmeter in the case. Screw in the six screws holding the ohmmeter in the case.

4-5. PERFORMANCE TEST.

WARNING

DANGEROUS VOLTAGES EXIST IN THIS EQUIPMENT

Do not come in contact with test leads or terminals during operation. Potentials as high as 550 Volts exist during operation.

DON'T TAKE CHANCES!

NOTE

Where cranking of the ohmmeter is required, adjust your cranking speed to the point where an increase in cranking speed does not effect the reading. This speed is approximately 160 rpm.

a. Test Potentials.

- (1) Set the electronic voltmeter ME-202C/U (EVM) to read DC Volts in the differential mode. Connect the EVM across the red and black ohmmeter terminals. Crank the ohmmeter and obtain an EVM reading. The EVM shall indicate 500 Volts minimum.
- (2) Repeat (1) above except connect a 10 Megohm resistor across the EVM test connections. The EVM shall indicate 450 Volts minimum.

b. Ripple voltage.

- (1) Repeat a. (1) except set the EVM to read AC Volts in the differential mode. The EVM indication shall not exceed 10% of the reading obtained in a. (1).
- (2) Repeat a. (2) except set the EVM to read AC Volts in the differential mode. The EVM indication shall not exceed 10% of the reading obtained in a. (2).
- (3) Remove the test connections.

c. Accuracy. Make connections to the red and black terminals of the ohmmeter as shown under the column headed, connections. Crank the ohmmeter after making the required connections. The ohmmeter shall indicate within  $\pm 1/16$ " of that shown under the column headed, indication.

<u>Connections</u>	<u>Indication</u>
None	Infinity
100 Megohms	100 Megohms
10 Megohms	10 Megohms
1 Megohm	1 Megohm
Short Circuit	0 Ohms



## APPENDIX A REFERENCES

The following publications contain information applicable to the operation and maintenance of Ohmmeter AN/PSM-43.

AR 55-38	Reporting of Transportation Discrepancies in Shipments.
AR 700-58	Report of Packaging and Handling Deficiencies.
MIL-F-14072	Index of Technical Publications; Technical Manuals, Technical Bulletins, Supply Manuals (Types 7, 8 and 9), Supply Bulletins and Lubrication Orders.
SB 11-573	Finishes for Ground Signal Equipment.
SB 38-100	Painting and Preservation Supplies Available for Field Use for Electronics Command Equipment.
SB 700-20	Preservation, Packaging and Packing Materials, Supplies and Equipment Used by the Army.
TM 11-6625-2724-12	Army Adopted/Other Items Selected for Authorization/List of Reportable Items.
TM 38-750	Operator's and Organizational Maintenance Manual: Voltmeter, Electronic ME-202C/U (NSN 6625-00-972-4046).
TM 750-244-2	The Army Maintenance Management System (TAMMS).
	Procedures for Destruction of Electronics Materiel to Prevent Enemy Use (Electronics Command).



## APPENDIX B

## COMPONENTS OF END ITEM LIST

---

Section I. INTRODUCTION

## B-1. Scope

This appendix lists integral components of and basic issue items for the AN/PSM-43 to help you inventory items required for safe and efficient operation.

## B-2. General

This Components of End Item List is divided into the following sections:

a. Section II. Integral Components of the End Item.

These items, when assembled, comprise the AN/PSM-43 and must accompany it whenever it is transferred or turned in. The illustrations will help you identify these items.

b. Section III. Basic Issue Items. Not applicable.

## B-3. Explanation of Columns

a. Illustration item number. The number used to identify item called out in the illustration.

b. National Stock Number. Indicates the National stock number assigned to the item and which will be used for requisitioning.

c. Description. Indicates the Federal item name and, if required, a minimum description to identify the item. The part number indicates the primary number used by the manufacturer, which controls the design and characteristics of the item by means of its engineering drawings, specifications, standards, and inspection requirements to identify an item or range of items. Following the part number, the Federal Supply Code for Manufacturers (FSCM) is shown in parentheses.

d. Location. Not applicable.

e. Usable on Code. Not applicable.

f. Quantity Required (Qty Reqd). This column lists the quantity of each item required for a complete major item.

g. Quantity. This cloumn is left blank for use during an inventory. Under the Rcvd column, list the quantity you actually receive on your major item. The Date columns are for your use when you inventory the major item.

Special Information

National stock numbers (NSN's) that are missing from section II have been applied for and will be added to this TM by future Change/Revision when they are entered in the Army Master Data File (AMDF). Until the NSN's are established and published, submit exception requisitions to: Commander, US Army Electronics Command, ATTN: DRSEL-MM, Fort Monmouth, New Jersey 07703 for the part required to support your equipment.



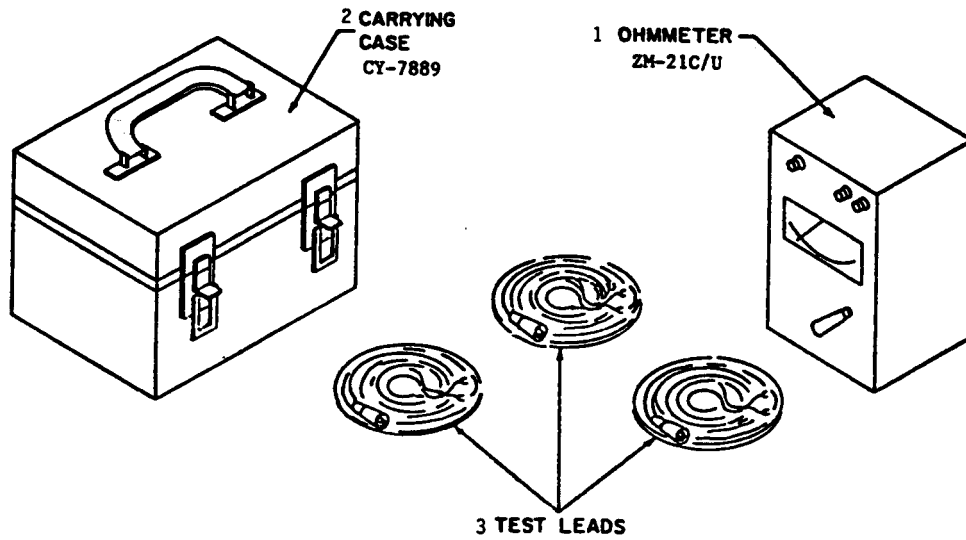

SECTION II COMPONENTS OF END ITEM

FOR OHMMETER AN/PSM-43

(1) ILLUS ITEM NO.	(2) NATIONAL STOCK NUMBER	(3) DESCRIPTION  (FSCM) AND PART NUMBER  USABLE ON CODE	(4) U/M	(5) QTY REQD
1		Ohmmeter: ZM-21C/U		
2		Case: CY-7889		
3		Cables (test leads)		



## APPENDIX D

MAINTENANCE ALLOCATION  
Section I. INTRODUCTION

---

1. General.

This appendix provides a summary of the maintenance operations for the Ohmmeter AN/PSM-43. It authorizes categories of maintenance for specific maintenance functions on repairable items and components and the tools and equipment required to perform each function. This appendix may be used as an aid in planning maintenance operations.

2. Maintenance Function.

Maintenance functions will be limited to and defined as follows:

a. Inspect. To determine the serviceability of an item by comparing its physical, mechanical, and/or electrical characteristics with established standards through examination.

b. Test. To verify serviceability and to detect incipient failure by measuring mechanical or electrical characteristics of an item and comparing those characteristics with prescribed standards.

c. Service. Operations required periodically to keep an item in proper operating condition, i.e., to clean (decontaminate), to preserve, to drain, to paint, or to replenish fuel, lubricants, hydraulic fluids, or compressed air supplies.

d. Adjust. To maintain, within prescribed limits, by bringing into proper or exact position, or by setting the operating characteristics to the specified parameters.

e. Align. To adjust specified variable elements of an item to bring about optimum or desired performance.

f. Calibrate. To determine and cause corrections to be made or to be adjusted on instruments or test measuring and diagnostic equipments used in precision measurement. Consists of comparisons of two instruments, one of which is a certified standard of known accuracy, to detect and adjust any discrepancy in the accuracy of the instrument being compared.

g. Install. The act of emplacing, seating, or fixing into position an item, part, module (component or assembly) in a manner to allow the proper functioning of the equipment or system.

h. Replace. The act of substituting a serviceable like type part, subassembly, or module (component or assembly) for an unserviceable counterpart.

i. Repair. The application of maintenance services (inspect, test, service, adjust, align, calibrate, replace) or other maintenance actions (welding, grinding, riveting, straightening, facing, remachining, or resurfacing) to restore serviceability to an item by correcting specific damage, fault, malfunction, or failure in a part, subassembly, module (component or assembly), end item, or system.

j. Overhaul. That maintenance effort (service/action) necessary to restore an item to a completely serviceable/operational condition as prescribed by maintenance standards (i.e., DMWR) in appropriate technical publications. Overhaul is normally the highest degree of maintenance performed by the Army. Overhaul does not normally return an item to like new condition.

k. Rebuild. Consists of those services/actions necessary for the restoration of unserviceable equipment to a like new condition in accordance with original manufacturing standards. Rebuild is the highest degree of material maintenance applied to Army equipment. The rebuild operation includes the act of returning to zero those age measurements (hours, miles, etc.) considered in classifying Army equipments/components.

3. Column Entries.

a. Column 1, Group Number. Column 1 lists group numbers, the purpose of which is to identify components, assemblies, subassemblies, and modules with the next higher assembly.

b. Column 2, Component/Assembly. Column 2 contains the noun names of components, assemblies, subassemblies, and modules for which maintenance is authorized.

c. Column 3, Maintenance Functions. Column 3 lists the functions to be performed on the item listed in column 2. When items are listed without maintenance functions, it is solely for the purpose of having the group numbers in the MAC and RPSTL coincide.

d. Column 4, Maintenance Category. Column 4 specifies, by the listing of a "worktime" figure in the appropriate subcolumn(s), the lowest level of maintenance authorized to perform the function listed in column 3. This figure represents the active time required to perform that maintenance function at the indicated category of maintenance. If the number or complexity of the tasks within the listed maintenance function vary at different maintenance categories, appropriate "worktime" figures will be shown for each category. The number of task-hours specified by the "worktime" figure represents the

average time required to restore an item (assembly, subassembly, component, module, end item or system) to a serviceable condition under typical field operating conditions. This time includes preparation time, troubleshooting time, and quality assurance/quality control time in addition to the time required to perform the specific tasks identified for the maintenance functions authorized in the maintenance allocation chart. Subcolumns of column 4 are as follows:

- C - Operator/Crew
- O - Organizational
- F - Direct Support
- H - General Support
- D - Depot

e. *Column 5, Tools and Equipment.* Column 5 specifies by code, those common tool sets, (not individual tools) and special tools, test, and support equipment required to perform the designated function.

f. *Column 6, Remarks.* Column 6 contains an alphabetic code which leads to the remark in Section IV, Remarks, which is pertinent to the item opposite the particular code.

#### 4. Tool and Test Equipment Requirements (Section III).

a. *Tool or Test Equipment Reference Code.* The numbers in this column coincide with the numbers used

in the tools and equipment column of the MAC. The numbers indicate the applicable tool or test equipment for the maintenance functions.

b. *Maintenance Category.* The codes in this column indicate the maintenance category allocated the tool or test equipment.

c. *Nomenclature.* This column lists the noun name and nomenclature of the tools and test equipment required to perform the maintenance functions.

d. *National/NATO Stock Number.* This column lists the National/NATO stock number of the specific tool or test equipment.

e. *Tool Number.* This column lists the manufacturer's part number of the tool followed by the Federal Supply Code for manufacturers (5-digit) in parentheses.

#### 5. Remarks (Section IV).

a. *Reference Code.* This code refers to the appropriate item in Section II, Column 6.

b. *Remarks.* This column provides the required explanatory information necessary to clarify items appearing in Section II.

(1) GROUP NUMBER	(2) COMPONENT/ASSEMBLY	(3) MAINTENANCE FUNCTION	(4) MAINTENANCE CATEGORY					(5) TOOLS AND EQPT.	(6) REMARKS
			C	O	F	H	D		
0	Ohmmeter AN/PSM-43	Inspect Service Test	0.1 0.2			0.5		Visual 6 1 thru 5	
1	Ohmmeter Assembly, ZN-21C/U	Inspect Service Test				0.1 0.2 0.5		1 1 1 thru 5	
2	Case, CY-7889	Inspect Service Replace				0.1 0.2 0.3		1 1 1	
3	Cables	Inspect Replace	0.1 0.2					Visual	

SECTION III TOOL AND TEST EQUIPMENT REQUIREMENTS  
FOR  
OHMMETER AN/PSM-43

TOOL OR TEST EQUIPMENT REF CODE	MAINTENANCE CATEGORY	NOMENCLATURE	NATIONAL/NATO STOCK NUMBER	TOOL NUMBER
1	H	Tool Kit, Electronic Equipment TK-101/G	5180-00-064-5178	
2	H	Resistor, Fxd Film 1 Megohm $\pm 1\%$	5905-00-433-9267	
3	H	Resistor, Fxd Film 10 Megohm $\pm 1\%$	5905-00-065-0585	
4	H	Resistor, Fxd Film 100 Megohm $\pm 1\%$	5905-00-049-8618	
5	H	Voltmeter, Electronic ME-202C/U	6625-00-972-4046	
6	H	Common tools necessary to the performance of this maintenance function are available to maintenance personnel for the maintenance category listed.		





By Order of the Secretary of the Army:

Official:

J.C. PENNINGTON  
Major General, United States Army  
The Adjutant General

EDWARD C. MEYER  
General, United States Army  
Chief of Staff

TM 11-6625-2981-14

DISTRIBUTION:

Active Army:

HISA (Ft Monmouth) (21)	USAICS (3)
USAINSCOM (2)	MAAG (1)
COE (1)	USARMIS (1)
TSG (1)	USAERDAA (1)
USAARENBD (1)	USAERDAW (1)
DARCOM (1)	Fort Gordon (10)
TRADOC (2)	Fort Carson
OS Maj Comd (4)	Army Dep (1) except
TECOM (2)	SAAD (30)
USACC (4)	TOAD (14)
MDW (1)	SHAD (2)
Armies (2)	Fort Gillem (10)
Corps (2)	USA Dep (1)
Svc Colleges (1)	Sig Sec USA Dep (1)
USASIGS (5)	Fort Richardson (CERCOM Ofc) (2)
USAADS (2)	Units org under fol TOE:
USAFAS (2)	(2 copies each unit)
USAARMS (2)	29-207
USAIS (2)	29-610
USAES (2)	

ARNG: None

USAR: None

For explanation of abbreviations used, see AR 310-50.





THEN... JOT DOWN THE DOPE ABOUT IT ON THIS FORM. CAREFULLY TEAR IT OUT. FOLD IT AND DROP IT IN THE MAIL!

SOMETHING WRONG WITH THIS PUBLICATION?

FROM (PRINT YOUR UNIT'S COMPLETE ADDRESS)

Commander  
Stateside Army Depot  
ATTN: AMSTA-US  
Stateside, N.J. 07703

DATE SENT

10 July 1975

PUBLICATION NUMBER

TM 11-5840-340-12

PUBLICATION DATE

23 Jan 74

PUBLICATION TITLE

Radar Set AN/PRC-76

BE EXACT PIN-POINT WHERE IT IS

PAGE NO	PARA-GRAPH	FIGURE NO	TABLE NO
---------	------------	-----------	----------

2-25	2-28		
------	------	--	--

3-10	3-3		
------	-----	--	--

		3-1	
--	--	-----	--

5-6	5-8		
-----	-----	--	--

		F03	
--	--	-----	--

IN THIS SPACE TELL WHAT IS WRONG AND WHAT SHOULD BE DONE ABOUT IT:

Recommend that the installation antenna alignment procedure be changed throughout to specify a 2° IFF antenna lag rather than 1°

REASON: Experience has shown that with only a 1° lag, the antenna servo system is too sensitive to wind gusting in excess of 25 knots, and has a tendency to rapidly accelerate and decelerate as it hunts, causing strain to the drive train. Hunting is minimized by adjusting the lag to 2° without degradation of operation.

Item 5, Function column. Change "2 db" to "3db."

REASON: The adjustment procedure the the TRANS POWER FAULT indicator calls for a 3 db (500 watts) adjustment to light the TRANS POWER FAULT indicator.

Add new step f.1 to read, "Replace cover plate removed in step e.1, above."

REASON: To replace the cover plate.

Zone C 3. On J1-2, change "+24 VDC to "+5 VDC."

REASON: This is the output line of the 5 VDC power supply. +24 VDC is the input voltage.

PRINTED NAME GRADE OR TITLE AND TELEPHONE NUMBER

SSG I. M. DeSpiritof 999-1776

SIGN HERE

DA FORM 2028-2 JUL 79

PREVIOUS EDITIONS ARE OBSOLETE.

P.S.--IF YOUR OUTFIT WANTS TO KNOW ABOUT YOUR RECOMMENDATION MAKE A CARBON COPY OF THIS AND GIVE IT TO YOUR HEADQUARTERS





FILL IN YOUR  
UNIT'S ADDRESS

FOLD BACK

DEPARTMENT OF THE ARMY

OFFICIAL BUSINESS

Commander  
US Army Communications and  
Electronics Materiel Readiness Command  
ATTN: DRSEL-ME-MQ  
Fort Monmouth, New Jersey 07703

FOLD BACK

TEAR ALONG DOTTED LINE



FILL IN YOUR  
UNIT'S ADDRESS

FOLD BACK

DEPARTMENT OF THE ARMY

OFFICIAL BUSINESS

Commander  
US Army Communications and  
Electronics Materiel Readiness Command  
ATTN: DRSEL-ME-MQ  
Fort Monmouth, New Jersey 07703

TEAR ALONG DOTTED LINE

FOLD BACK





FILL IN YOUR  
UNIT'S ADDRESS

FOLD BACK

DEPARTMENT OF THE ARMY

OFFICIAL BUSINESS

Commander  
US Army Communications and  
Electronics Materiel Readiness Command  
ATTN: DRSEL-ME-MQ  
Fort Monmouth, New Jersey 07703

FOLD BACK

TEAR ALONG DOTTED LINE



